



# Ruijie RG-WS7110 Wireless Access Controller

## Hardware Installation and Reference Guide

## Copyright

Copyright © 2025 Ruijie Networks

All rights are reserved in this document and this statement.

Without the prior written consent of Ruijie Networks, no organization or individual is permitted to reproduce, extract, back up, modify, or distribute the content of this document in any manner or form. It is also prohibited to translate the document into other languages or use any or all parts of it for commercial purposes.

 and  trademarks are owned by Ruijie Networks.

All other trademarks or registered trademarks mentioned in this document are owned by their respective owners.

## Disclaimer

The products, services, or features that you purchase are subject to commercial contracts and terms. It is possible that some or all of the products, services, or features described in this document may not be available for purchase or use. Unless agreed upon otherwise in the contract, Ruijie Networks does not provide any explicit or implicit statements or warranties regarding the content of this document.

The names, links, descriptions, screenshots, and any other information regarding third-party software mentioned in this document are provided for your reference only. Ruijie Networks does not explicitly or implicitly endorse or recommend the use of any third-party software and does not make any assurances or guarantees concerning the applicability, security, or legality of such software. You should choose and use third-party software based on your business requirements and obtain proper authorization. Ruijie Networks assumes no liability for any risks or damages arising from your use of third-party software.

The content of this document is subject to constant change due to product version upgrades or other reasons. Thus, Ruijie Networks reserves the right to modify the content of the document without prior notice or prompt.

This manual serves solely as a user guide. While Ruijie Networks endeavors to ensure the accuracy and reliability of the content when compiling this manual, it does not guarantee that the content of the manual is free of errors or omissions. All information contained in this manual does not constitute any explicit or implicit warranties.

## Personal Data Statement

During the operation or troubleshooting of the products, services, or features you have purchased, certain personal data of users may be collected or used. Therefore, it is essential for you to establish and implement appropriate privacy policies, in compliance with the relevant laws and regulations of the applicable countries or regions, to ensure the complete protection of users' personal data.

If Ruijie Networks is involved in this process, we will strictly adhere to the relevant laws and regulations of the applicable countries or regions and take all necessary actions to safeguard users' personal data.

When discarding, reclaiming, or reusing a device, please ensure to back up or clear any stored data to avoid data leakage. For assistance, please contact our after-sales technical support.

# Preface

## Intended Audience

This document is intended for:

- Network engineers
- Technical support and servicing engineers
- Network administrators

## Technical Support

- Ruijie Networks website: <https://www.ruijie.com/>
- Online support center: <https://www.ruijie.com/support>
- Case portal: <https://caseportal.ruijie.com>
- Community: <https://community.ruijie.com/>
- Email support: [EBGITSC@ruijie.com.cn](mailto:EBGITSC@ruijie.com.cn)
- Live chat: <https://www.ruijie.com/rita>
- Documentation feedback: [doc@ruijie.com.cn](mailto:doc@ruijie.com.cn)

## Conventions

### 1. Signs

The signs used in this document are described as follows:

---

 **Danger**  
An alert that contains important safety instructions. Before you work on any equipment, be aware of the hazards involved and be familiar with standard practices in case of accidents.

---

 **Warning**  
An alert that calls attention to important rules and information that if not understood or followed can result in data loss or equipment damage.

---

 **Caution**  
An alert that calls attention to essential information that if not understood or followed can result in function failure or performance degradation.

---

 **Note**  
An alert that contains additional or supplementary information that if not understood or followed will not lead to serious consequences.

---

 **Specification**  
An alert that contains a description of product or version support.

---

## **2. Notes**

The manual provides configuration information, including models, port types, and command line interfaces, for reference purposes only. In the event of any discrepancy or inconsistency between the manual and the actual version, the actual version shall take precedence.

# Contents

1 Overview .....	1
1.1 About the RG-WS7110 .....	1
1.2 Hardware Features .....	1
1.3 Package Contents.....	4
1.4 Technical Specifications .....	4
1.4.1 Dimensions and Weight.....	4
1.4.2 Port Specifications .....	5
1.4.3 Power Supply and Consumption .....	5
1.4.4 Environment and Reliability .....	6
1.4.5 Regulatory Compliance.....	6
1.5 LEDs and Button.....	6
2 Preparing for Installation .....	8
2.1 Safety Guidelines.....	8
2.1.1 General Safety Guidelines.....	8
2.1.2 Chassis-Lifting Guidelines .....	8
2.1.3 Electric Safety .....	8
2.1.4 Storage Guidelines .....	9
2.2 Site Requirements .....	9
2.2.1 Floor Loading .....	9
2.2.2 Airflow.....	9
2.2.3 Space .....	9
2.2.4 Temperature and Humidity.....	9

2.2.5 Cleanliness.....	10
2.2.6 Grounding .....	11
2.2.7 ESD Protection .....	11
2.2.8 Preventing Electromagnetic Interference .....	12
2.2.9 Surge Protection .....	12
2.2.10 Installation Site.....	12
2.3 Tools .....	12
3 Installing the Access Controller.....	13
3.1 Installation Flowchart.....	13
3.2 Before You Begin.....	14
3.3 Precautions .....	14
3.4 Installing the Access Controller .....	14
3.4.1 Installing the RG-WS7110 in a Cabinet or on a Workbench .....	14
3.4.2 Installing the Power Supply .....	14
3.4.3 Installing the Grounding Cable .....	15
3.5 Connecting the Console Cable.....	15
3.6 Bundling Cables.....	16
3.6.1 Precautions .....	16
3.6.2 Steps .....	16
3.7 Checklist After Installation .....	16
3.7.1 Checking the Device .....	16
3.7.2 Checking the Cable Connection .....	16
3.7.3 Checking the Power Supply.....	16
4 Commissioning.....	17

4.1 Setting Up the Configuration Environment .....	17
4.1.1 Precautions .....	17
4.1.2 Connecting the Console Cable .....	17
4.1.3 Setting Parameters .....	18
4.2 Powering on the Device .....	20
4.2.1 Checklist Before Power-on .....	20
4.2.2 Checklist After Power-on .....	20
5 Monitoring and Maintenance .....	21
5.1 Monitoring .....	21
5.1.1 LEDs .....	21
5.1.2 CLI Commands .....	21
5.2 Remote Maintenance .....	21
5.3 Hardware Maintenance .....	21
5.3.1 Replacing the Lithium Battery .....	21
6 Troubleshooting .....	22
6.1 Troubleshooting Flowchart .....	22
6.2 Common Faults .....	22
6.2.1 The Ethernet Port Does Not Work After the Ethernet Cable Is Plugged In .....	22
6.2.2 LED Is Off for a Long Time .....	22
6.2.3 System LED Blinks Green for a Long Time .....	22
6.2.4 Troubleshooting Power Failures .....	23
6.2.5 Troubleshooting System Failures .....	23
7 Appendix .....	24
7.1 Connectors and Media .....	24

7.2 Cabling Recommendations.....	26
7.3 Optical Transceivers .....	29
7.3.1 1GE SFP Transceivers .....	29
7.3.2 10GE SFP+ Transceivers .....	31

# 1 Overview

## 1.1 About the RG-WS7110

The RG-WS7110 is a next-generation high-performance wireless access controller (AC) launched by Ruijie Networks. The RG-WS7110 supports 100 V AC to 240 V AC power supply. With eight 10/100/1000BASE-T ports, two 1GE SFP/RJ45 combo ports, and two 10GE SFP+ ports, the RG-WS7110 can uniformly manage Ruijie wireless access points (APs), simplifying wireless networking.

The RG-WS7110 can be deployed on a Layer 2 or Layer 3 network without any architecture or hardware changes to maintain communications with APs. This seamless integration capability ensures the security and stability of wireless networks and simplifies deployment and maintenance, providing an efficient and flexible wireless access solution for customers.

## 1.2 Hardware Features

The RG-WS7110 provides eight 10/100/1000BASE-T ports, two 1GE SFP/RJ45 combo ports, two 10GE SFP+ ports, two USB 3.0 ports (compatibility with USB 2.0), one console port, one Reset button, and two LEDs on the front panel.

Figure 1-1 Front Top View of the RG-WS7110



Figure 1-2 Left Top View of the RG-WS7110



Figure 1-3 Front Panel of the RG-WS7110

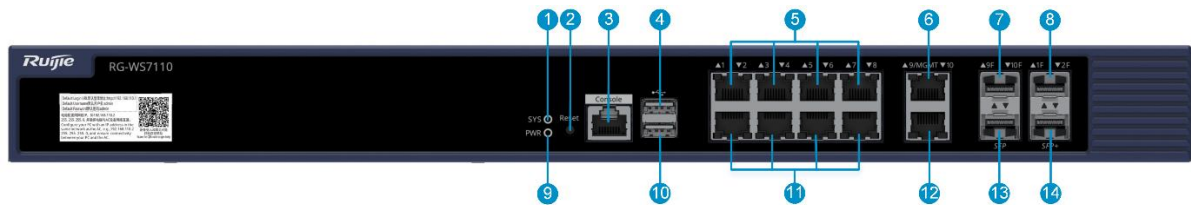

Table 1-1 Components on the Front Panel

No.	Component	Description
1	System (SYS) status LED	Used to indicate the working status of the system.
2	Reset button	Used to reboot the device or restore the device to factory settings.
3	Console port	Connected to a serial port for device management.
4/10	USB port	Connected to a storage device.
5/11	Eight 1GE 10/100/1000BASE-T ports	Service ports for data transmission.

No.	Component	Description
6/7/12/13	Two 1GE SFP/RJ45 combo ports	Service ports for data transmission. <ul style="list-style-type: none"> <li>When used as RJ45 ports, the ports support 10/100/1000BASE-T.</li> <li>Port 6 (silkscreen: 9/MGMT) can be used as a management port.</li> </ul>
8/14	Two 10GE SFP+ ports	Service port for data transmission.
9	Power (PWR) LED	Used to indicate the working status of the power supply.

**Note**

A combo port consists of an optical Ethernet port and an RJ45 Ethernet port on the panel and can be used as the optical or RJ45 port at one time. When either of the Ethernet ports is working, the other port is automatically shut down. You can select a port type as required.

**Figure 1-4 Rear Panel of the RG-WS7110**



**Table 1-2 Components on the Rear Panel**

No.	Component	Description
1	Grounding stud	Connected to the ground with a grounding cable.
2	Power connector	Connected to an AC power supply to source power to the device.

**Note**

- The product nameplate is located at the bottom of the device.
- The network access license is located on the packaging material or the equipment.

## 1.3 Package Contents

Table 1-3 Package Contents

No.	Item	Quantity
1	RG-WS7110 AC	1
2	Power cord	1
3	Rubber pad	4
4	M4 x 8 mm Phillips countersunk screw	6
5	<i>Warranty Card and Hazardous Substance Table</i>	1
6	Console cable	1
7	Grounding wire	1
8	Rack-mount bracket	2
9	Power cord retention clip	1
10	<i>Quick Installation Guide</i>	1

## 1.4 Technical Specifications

### 1.4.1 Dimensions and Weight

Table 1-4 Dimensions and Weight

Dimensions and Weight	RG-WS7110
Unit dimensions (W x D x H)	440 mm x 200 mm x 43.6 mm (17.32 in. x 7.87 in. x 1.72 in., without mounting bracket) 486.2 mm x 205 mm x 43.6 mm (19.14 in. x 8.07 in. x 1.72 in., including mounting bracket)
Rack height	1 RU
Unit weight	2.7 kg (5.95 lbs)
Shipping weight	3.5 kg (7.72 lbs)
Mounting	Rack-mount

## 1.4.2 Port Specifications

Table 1-5 Ports Specifications

Ports Specifications	RG-WS7110
Fixed service port	8 x 10/100/1000BASE-T ports 2 x 1GE SFP/RJ45 combo ports <ul style="list-style-type: none"> <li>● RJ45 ports support 10/100/1000BASE-T.</li> <li>● Port 9/MGMT can also be used as a management port.</li> </ul> 2 x 10GE SFP+ ports
Fixed management port	1 x RJ45 console port 2 x USB 3.0 ports, compatibility with USB 2.0
Status LED	1 x system status LED 1 x power LED 8 x 10/100/1000BASE-T port LEDs 2 x 1GE SFP/RJ45 combo port LEDs 2 x 10GE SFP+ port LEDs
Button	1 x Reset button

## 1.4.3 Power Supply and Consumption

Table 1-6 Power Supply and Consumption

Power Supply and Consumption	RG-WS7110
Maximum power consumption	30 W
Power module redundancy	Not supported
Power input	100 V AC to 240 V AC, 50 Hz to 60 Hz
Power output	12 V/3.33 A

---

 **Warning**

The fuse in the power supply cannot be removed.

---

## 1.4.4 Environment and Reliability

Table 1-7 Environmental and Reliability

Environment and Reliability	RG-WS7110
Temperature	<p>Operating temperature: 0°C to 45°C (32°F to 113°F)</p> <p>Storage temperature: -40°C to +70°C (-40°F to +158°F)</p> <p>Note: At an altitude in the range of 1,800–4,000 m (5,905.51–13,123.36 ft.), every time the altitude increases by 220 m (721.78 ft.), the maximum temperature decreases by 1°C (1.8°F).</p>
Altitude	<p>Operating altitude: -500 m to +4,000 m (-1,640.42 ft. to +13,123.36 ft.)</p> <p>Storage altitude: -500 m to +4,000 m (-1,640.42 ft. to +13,123.36 ft.)</p>
Humidity	<p>Operating humidity: 10% RH to 90% RH (non-condensing)</p> <p>Storage humidity: 5% RH to 95% RH (non-condensing)</p>

## 1.4.5 Regulatory Compliance

Table 1-8 Regulatory Compliance

Regulatory Compliance	RG-WS7110
Safety regulations	IEC 62368-1 and EN 62368-1
EMC regulations	EN 55032, EN 55035, EN 61000-3-3, EN IEC 61000-3-2, and ETSI EN 300 386

 Note

- For more country-specific regulatory information and approvals, contact your local sales agency.
- Ruijie wireless products provide only secure and reliable network protocols and communication ports by default. For details, see [Ruijie Default Protocols and Ports for Wireless Products](#). Proper firewall and security policies can be implemented based on this document to ensure the normal operation of wireless services.

 Warning

The equipment is not suitable for use in locations where children are likely to be present.

## 1.5 LEDs and Button

Table 1-9 LEDs

LED Type	LED Status	Frequency	Description
PWR LED	Off	N/A	The device is not powered on.

LED Type	LED Status	Frequency	Description
	Solid green	N/A	The device is powered on.
SYS LED	Off	N/A	A system error occurs.
	Blinking green	On for 500 ms Off for 500 ms	The system is being initialized.
	Solid green	N/A	Initialization is complete.
	Solid red	N/A	An alarm occurs.
Electrical ports 1–10 Link/ACT LED	Off	N/A	The port is not connected.
	Solid green	N/A	The port is connected at a rate of 1000 Mbps.
	Blinking green	On for 166 ms Off for 166 ms	The port is sending or receiving data at a rate of 1000 Mbps.
	Solid orange	N/A	The port is connected at a rate of 10 Mbps or 100 Mbps.
	Blinking orange	On for 166 ms Off for 166 ms	The port is sending or receiving data at a rate of 10 Mbps or 100 Mbps.
SFP/SFP+ port LED	Off	N/A	The port is not connected.
	Solid green	N/A	The port is connected at a rate of 1 Gbps or 10 Gbps.
	Blinking green	On for 166 ms Off for 166 ms	The port is sending or receiving data at a rate of 1 Gbps or 10 Gbps.

**Table 1-10 Reset Button**

Button	Action	Description
Reset button	Press the button for less than 3 seconds.	Restart the device.
	Press the button for more than 3 seconds	Restore the device to factory settings.

# 2 Preparing for Installation

## 2.1 Safety Guidelines

---

### Note

- To avoid personal injury and device damage, carefully read the safety precautions before you install the device.
  - The following safety precautions do not cover all possible dangers.
- 

### 2.1.1 General Safety Guidelines

---

#### Warning

In a domestic environment, this product may cause radio interference in which case the user may be required to take adequate measures.

---

- Do not expose the device to high temperature, dusts, or harmful gases. Do not install the device in an inflammable or explosive environment. Keep the device away from Electro-Magnetic Interference (EMI) sources such as large radar stations, radio stations, and substations. Do not subject the device to unstable voltage, vibration, and noises.
- The installation site should be free from water flooding, seepage, dripping, or condensation. The installation site should be selected according to communication network planning and technical requirements for communication equipment, and considerations such as climate, hydrology, geology, earthquake, electrical power, and transportation.
- The installation site should be dry. You are not advised to install the device in a place near the sea. Keep the device at least 500 meters (1640.42 ft.) away from the ocean. You are advised not to orient the device toward the direction of sea breeze.
- Do not place the device in walking areas.
- During installation and maintenance, do not wear loose clothes, ornaments, or any other things that may be hooked by the chassis.
- Keep tools and components away from the walking area.

### 2.1.2 Chassis-Lifting Guidelines

- Avoid handling the device frequently.
- Cut off all power supplies and unplug all power cords and cables before handling the device.

### 2.1.3 Electric Safety

---

#### Warning

- Improper or incorrect electric operations may cause a fire, electric shock, and other accidents, and lead to severe and fatal personal injury and device damage.
  - Direct or indirect touch through a wet object on high-voltage and mains supply can bring a fatal danger.
-

- Observe local regulations and specifications during electric operations. Only personnel with relevant qualifications can perform such operations.
- Check potential risks in the work area, such as wet floor.
- Learn about the position of the indoor emergency power switch before installation. Cut off the power switch in the case of accidents.
- Make sure that the device is powered off when you cut off the power supply.
- Do not place the device in a wet position, and keep it away from liquid.
- Keep the device away from grounding and surge protection facility for power equipment.
- Keep the device away from radio stations, radar stations, high-frequency and high-current devices, microwave ovens, and other high-power wireless devices.

### 2.1.4 Storage Guidelines

To ensure normal operation of the device, store the device in an environment based on the storage temperature or humidity requirements described in [1.4.4 Environment and Reliability](#).

---

 **Caution**

If the device has been powered off for more than 18 months, power on the device and run it for consecutive 24 hours to activate the device.

---

## 2.2 Site Requirements

The device must be installed and used indoors. For normal operation and prolonged service life of the device, the installation site must meet the following requirements.

### 2.2.1 Floor Loading

Evaluate the weight of the device and its accessories (such as the mounting bracket and power supply), and ensure that the installation site can bear the weight.

### 2.2.2 Airflow

Reserve sufficient space in front of air vents to ensure normal heat dissipation. After various cables are connected, bundle the cables or place them in the cable management arm to avoid blocking air inlets.

### 2.2.3 Space

Do not install the device against the wall. Instead, maintain a minimum clearance of 400 mm (15.75 in.) around the device for ventilation and maintenance.

### 2.2.4 Temperature and Humidity

To ensure the normal operation and prolonged service life of the device, maintain an appropriate temperature and humidity in the equipment room.

The equipment room with too high or too low temperature and humidity for a long period may damage the device.

- In an environment with high relative humidity, the insulating material may have poor insulation or even leak

electricity.

- In an environment with low relative humidity, the insulating strip may dry and shrink, resulting in screw loosening.
- In a dry environment, internal circuits are prone to static electricity.
- A high temperature can accelerate the aging process of insulation materials, greatly reducing the reliability of the device and severely affecting its service life.

---

**Note**

The ambient temperature and humidity of the device are measured at the point that is 1.5 m (4.92 ft.) above the floor and 0.4 m (1.31 ft.) before the device when there is no protective plate in front or at the back of the device.

---

## 2.2.5 Cleanliness

Dust poses a major threat to the device. The indoor dust takes on a positive or negative static electric charge when falling on the device, causing poor contact of the metallic joint. Such electrostatic adhesion may occur more easily when the relative humidity is low, not only affecting the service life of the device, but also causing communication faults. The following table describes the requirements for the dust content and granularity in the machine room.

**Table 2-1 Requirements for Dust**

Dust	Unit	Maximum Quantity
Dust particles (diameter $\leq 0.5 \mu\text{m}$ )	Particles/m <sup>3</sup>	$\leq 1.4 \times 10^7$
Dust particles ( $0.5 \mu\text{m} < \text{diameter} \leq 1 \mu\text{m}$ )	Particles/m <sup>3</sup>	$\leq 7 \times 10^5$
Dust particles ( $1 \mu\text{m} < \text{diameter} \leq 3 \mu\text{m}$ )	Particles/m <sup>3</sup>	$\leq 2.4 \times 10^5$
Dust particles ( $3 \mu\text{m} < \text{diameter} \leq 5 \mu\text{m}$ )	Particles/m <sup>3</sup>	$\leq 1.3 \times 10^5$

Apart from dust, the salt, acid, and sulfide in the air of the equipment room must meet strict requirement. These harmful substances will accelerate metal corrosion and component aging. Therefore, the equipment room should be properly protected against the intrusion of harmful gases, such as sulfur dioxide, hydrogen sulfide, nitrogen dioxide, and chlorine gas. The following table lists limit values for harmful gases.

**Table 2-2 Requirements for Gases**

Gas	Average (mg/m <sup>3</sup> )	Maximum (mg/m <sup>3</sup> )
Sulfur dioxide (SO <sub>2</sub> )	0.2	1.5
Hydrogen sulfide (H <sub>2</sub> S)	0.006	0.03
Nitrogen dioxide (NO <sub>2</sub> )	0.04	0.15
Ammonia gas (NH <sub>3</sub> )	0.05	0.15
Chlorine gas (Cl <sub>2</sub> )	0.01	0.3

---

**Note**

**Average** refers to the average value of harmful gases measured in one week. **Maximum** is the upper limit of the harmful gas measured in one week for up to 30 minutes every day.

---

## 2.2.6 Grounding

Reliable grounding is the foundation for stable and reliable device operations, and the prerequisite for lightning protection and interference resistance. Carefully check the grounding conditions at the installation site according to the grounding specifications, and complete grounding properly based on the actual situation.

- **Safety Grounding**

Ensure that the cabinet and power distribution device are securely grounded when the device uses the AC power supply. Otherwise, electric shock may occur when the insulation resistance between the power supply inside the device and the enclosure becomes small.

---

**Caution**

The building should provide a protective ground connection to ensure that the device is connected to a protective ground.

---

- **Lightning Grounding**

The lightning protection system of facilities is standalone, and is composed of a lightning rod, a down conductor, and a connector connected to the grounding system. The grounding system is usually used for power reference grounding and safety grounding of the rack. Lightning grounding is required only for facilities and is not required for the device.

- **EMC Grounding**

Grounding required for electromagnetic compatibility includes shielded grounding, filter grounding, noise and interference suppression, and level reference. These are the overall grounding requirements. The grounding resistance should be smaller than 1 ohm. The ground lugs of the rack must be connected to the ground before the device is running

## 2.2.7 ESD Protection

The device is designed with ESD protection. However, strong static electricity may damage the circuit board. Static electricity in the communication network connected to the device mainly originates from two sources:

- Outdoor high-voltage transmission lines, lightning, and other external electric fields.
- Internal systems such as indoor flooring materials and overall structure of the device.

To prevent damage caused by static electricity, pay attention to the following:

- Properly ground the device and floor.
- Keep the indoor installation environment clean and free of dust.
- Maintain appropriate temperature and humidity.
- Wear an anti-ESD wrist strap and clothes when you touch the circuit board of the device.
- Place the disassembled circuit board on an anti-ESD workbench or in an anti-ESD bag with its front panel

facing upward.

- When observing or handling a disassembled circuit board, avoid directly touching the components on the circuit board with your bare hands.

## 2.2.8 Preventing Electromagnetic Interference

- Take effective measures to prevent interference from power grid to the power supply system.
- Keep the device far away from the grounding facility or lightning protection facility of the power device.
- Keep the device far away from high-frequency devices such as the high-power radio transmitting station and radar launcher.
- Take electromagnetic shielding measures when necessary.

## 2.2.9 Surge Protection

The device can guard against lightning strikes. As an electric device, too strong lightning strikes may still damage the device. Take the following surge protection measures:

- Ensure that the grounding cable of the rack is in good contact with the ground.
- Ensure that the neutral point of the equipment power socket is in good contact with the ground.
- You are advised to install a power lightning arrester in front of the power input end to enhance surge protection for the power supply.

## 2.2.10 Installation Site

Regardless of whether the device is installed in a cabinet or on a workbench, ensure that the following conditions are met:

- Maintain a proper clearance around air intakes and outlets for heat dissipation.
- Ensure that the rack and workbench have a good ventilation and cooling system. In hot regions, install air conditioners.
- Ensure that the installation site is sturdy enough to support the weight of the device and its accessories.
- Ensure that the installation site is properly grounded.

## 2.3 Tools

**Table 2-3 Tools**

<b>Common Tools</b>	Phillips screwdriver, Ethernet cable, cage nuts, diagonal pliers, and cable ties
<b>Dedicated Tools</b>	ESD-preventive gloves, wire strippers, crimping pliers, and wire cutters
<b>Relevant Devices</b>	HUB or switch, configuration terminal (such as a PC with HyperTerminal), and power socket

### Note

The RG-WS7110 is delivered without a tool kit. The tool kit is customer-supplied.

# 3 Installing the Access Controller

The RG-WS7110 must be fixed and used indoors.

---

**⚠ Caution**

Before installing the equipment, ensure that guidelines and requirements in Chapter 2 have been met.

---

## 3.1 Installation Flowchart

The installation flowchart is as follows.

**Figure 3-1 Installation Procedure**

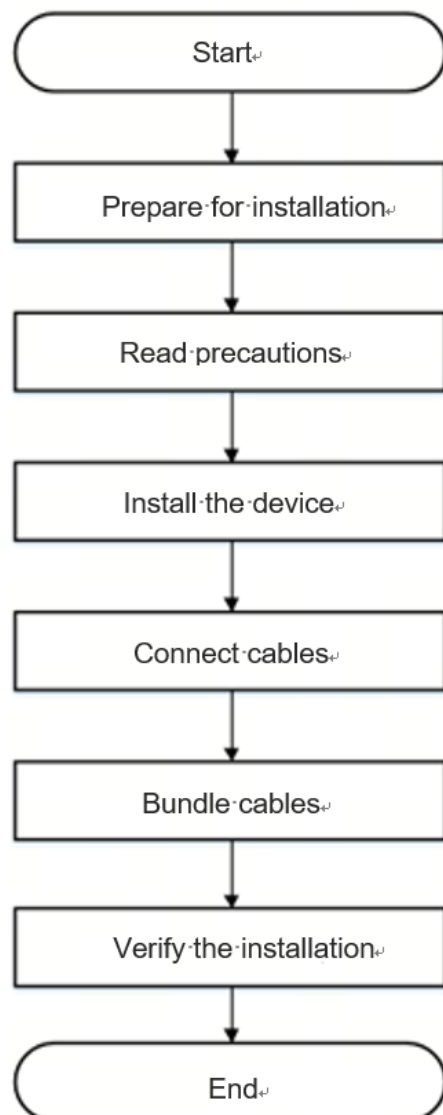

## 3.2 Before You Begin

Carefully plan and arrange the installation location, networking, power supply, and cabling before installing the device.

Confirm the following requirements before installation:

- The installation site should provide sufficient space for heat dissipation.
- The installation site meets the temperature and humidity requirements of the device.
- The power supply and required current are available in the installation location.
- The Ethernet cables are deployed in the installation location.
- The selected power supply meets the system power requirements.
- Locate the indoor emergency power switch before installation. Cut off the power in case of accidents.

## 3.3 Precautions

To ensure normal operation and prolong the service life of the device, observe the following safety precautions:

- Do not power on the device during installation.
- Place the device in a well-ventilated environment.
- Do not expose the device to high temperature.
- Keep the device away from high-voltage power cables.
- Install the device indoors.
- Do not expose the device to a thunderstorm or strong electric field.
- Keep the device clean and dust-free.
- Cut off the power supply before cleaning the device.
- Do not wipe the device with a damp cloth.
- Do not wash the device with liquid.
- Do not open the enclosure when the device is working.
- Secure the device properly.

## 3.4 Installing the Access Controller

### 3.4.1 Installing the RG-WS7110 in a Cabinet or on a Workbench

Installing the RG-WS7110 in a Cabinet: The RG-WS7110 is designed to adapt to a 19-inch standard cabinet. Use the provided mounting accessories to install the RG-WS7110 in a cabinet.

### 3.4.2 Installing the Power Supply

The RG-WS7110 adopts an AC power supply: 100 V AC to 240 V AC, 50 Hz to 60 Hz. Make sure that the power supply meets the requirements.

- (1) Connect one end of the power supply delivered with the RG-WS7110 to the AC power connector on the RG-WS711, and the other end to the AC socket.

- (2) Check whether the power LED on the front panel of the RG-WS7110 is on. If the LED is on, the power supply is connected correctly.

### 3.4.3 Installing the Grounding Cable

Connect the grounding cable with an OT terminal to the ground stud on the rear panel of the RG-WS7110.

**Figure 3-2** Grounding the RG-WS7110

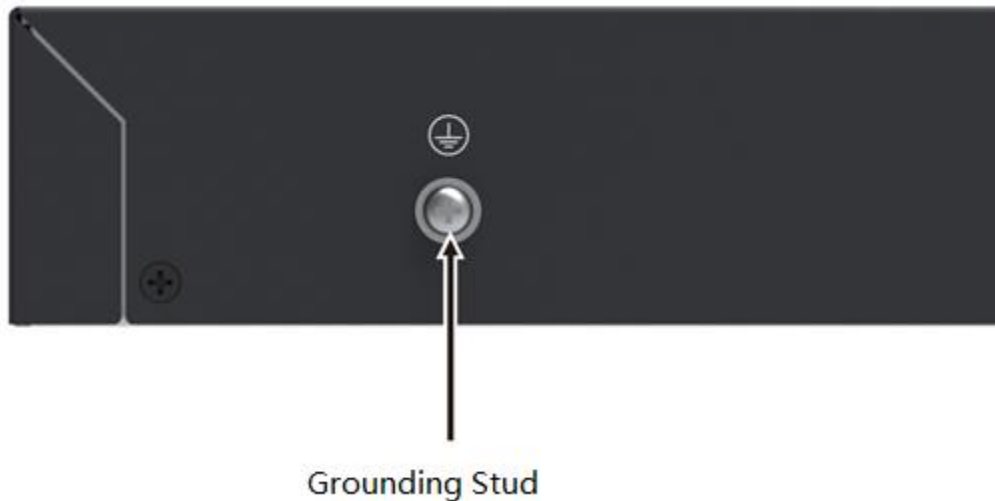

## 3.5 Connecting the Console Cable

The RG-WS7110 provides a console port that complies with the EIA/TIA-232 asynchronous serial standard. You can perform local configuration of the RG-WS7110 through this port. The following table describes the console port attributes. If you configure the RG-WS7110 through the web system, you do not need to connect the console.

**Table 3-1** Console Attributes

Parameter	Description
Connector	RJ-45
Interface standard	Asynchronous EIA/TIA-232
Baud rate	9,600 bps (default), 57,600 bps, and 115,200 bps
Supported services	<ul style="list-style-type: none"> <li>● Command line interface (CLI)</li> <li>● Connected to a character terminal</li> <li>● Used as an asynchronous interface to provide terminal access services.</li> </ul>

Connect one end of the provided console cable to the console port of the RG-WS7110, and the other end to the DB-9 male connector of the microcomputer used for device configuration.

## 3.6 Bundling Cables

### 3.6.1 Precautions

- Bundle the power cord and other cables in a visually pleasing way.
- Make sure that the twisted pair cables at the connectors have natural bends or bends of large radius when bundling the twisted pair cables.
- Do not bundle the twisted pair cables too tightly, as this may reduce the cable life and transmission performance.

### 3.6.2 Steps

- (1) Bundle the dropping parts of the twisted pair cables and route them to the port of the device.
- (2) Fasten the twisted pair cables to the cable management trough of the mounting bracket.
- (3) Extend the twisted pair cables under the device and route them in a straight line.

## 3.7 Checklist After Installation

### 3.7.1 Checking the Device

- If the device is installed in the cabinet, verify that the installation angle iron of the cabinet and the device is secured properly. If the device is installed on the workbench, verify that there is enough space around the device for heat dissipation and whether the workbench is sturdy.
- Verify that the external power supply matches the device.
- Verify that the front and rear cabinet doors can be closed after installing the device.
- Verify that the cabinet is properly fixed and will not move or tilt.
- Verify that the device and cables are properly installed in the cabinet.
- Verify that the grounding cable is correctly connected.
- Verify that the device is correctly connected to other devices, such as the configuration terminal.

### 3.7.2 Checking the Cable Connection

- Verify that the twisted pair cables match the port types.
- Verify that the cables are properly bundled.

### 3.7.3 Checking the Power Supply

- Verify that the power cord is properly connected and meets safety requirements.
- Verify that the AC works properly after power-on.

# 4 Commissioning

## 4.1 Setting Up the Configuration Environment

### 4.1.1 Precautions

Connect the AC power cord to the AC power connector on the RG-WS7110 to power on the RG-WS7110. When setting up the environment, pay attention to the following:

- When the RG-WS7110 is powered by the AC power supply, ensure that the power cord is properly connected and meets safety requirements.
- Connect an AP to the RG-WS7110 using a twisted pair cable.
- When a PC is connected to the console port of the RG-WS7110 for commissioning, ensure that the RG-WS7110 are properly grounded.

### 4.1.2 Connecting the Console Cable

- (1) Connect a PC to the console port of the RG-WS7110 using the console cable.

Figure 4-1 Connecting the Console Cable

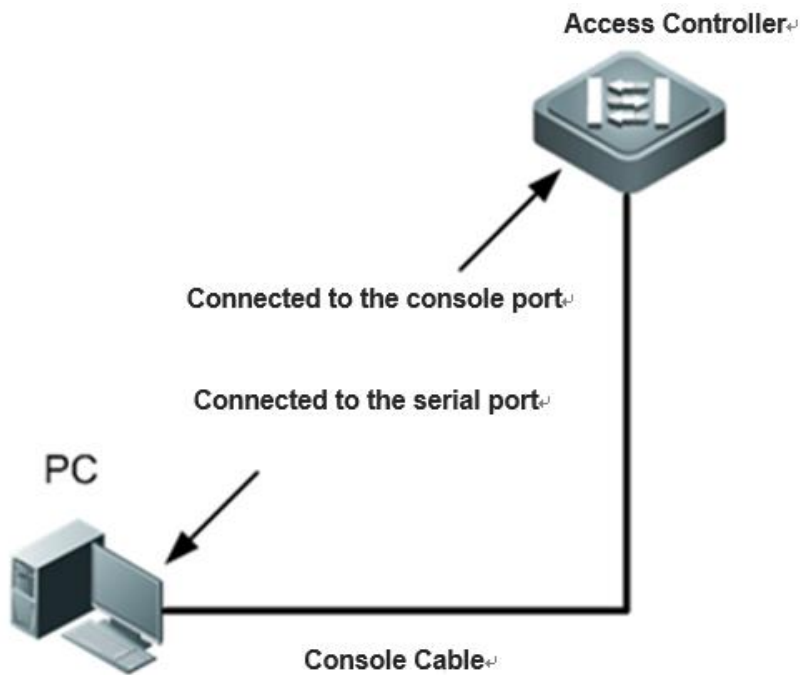

- (2) Connect the DB-9 connector of the console cable to the serial port of the PC.
- (3) Connect the RJ-45 connector of the console cable to the console port of the RG-WS7110.

### 4.1.3 Setting Parameters

When configuring the RG-WS7110 for the first time, use the console port for configuration. If you use a PC, run a terminal emulation program such as HyperTerminal provided by the Windows operating system. HyperTerminal is used as an example to illustrate the procedure.

- (1) Navigate to **Start > All Programs > Accessories > Communications** and select **HyperTerminal**. The **Location Information** dialog box will appear.
- (2) Click **Cancel**. The **Connection Description** dialog box will appear.

Figure 4-2 Creating a Connection



- (3) In the **Name** box, enter the new connection name and click **OK**. The **Connect To** dialog will appear. From the **Connect using** drop-down list, select a COM port to be used.

Figure 4-3 Selecting a Serial Port



- (4) Click **OK**. The **COM1 Properties** dialog box will appear. Select the following settings: Bits per second: 9600 (115200 during startup process; 9600 in main program); Data bits: 8; Parity check: None; Stop bit: 1; Flow control: None.

Figure 4-4 Configuring the Communication Parameters of the Serial Port

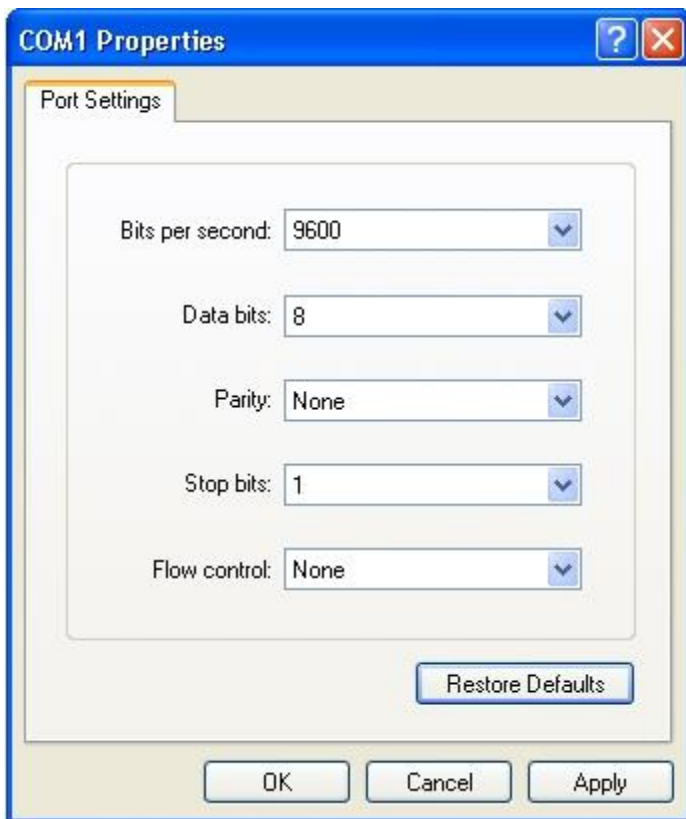

(5) Click **OK** and HyperTerminal window will appear.

## 4.2 Powering on the Device

### 4.2.1 Checklist Before Power-on

- Verify that the power cord is properly connected and the power supply meets the requirements.
- Verify that the input voltage meets the requirement and the console cable is properly connected.
- Verify that the PC or terminal is powered on and properly set up for commissioning.

### 4.2.2 Checklist After Power-on

After power-on, you are advised to check the following to ensure the normal operation of the device:

- Verify that there are system logs printed on the configuration interface of the device.
- Verify that the LEDs work normally.
- Verify that the main program is loaded properly.
- Verify that the device time is consistent with Beijing time.
- Verify that service ports can forward data properly.

# 5 Monitoring and Maintenance

## 5.1 Monitoring

### 5.1.1 LEDs

You can observe the LEDs to monitor the device in operation.

### 5.1.2 CLI Commands

You can run related commands on the CLI of the device to remotely monitor the device status, including:

- Port configuration and status
- System logs

---

 **Note**

For details about the commands, see the corresponding configuration guide.

---

## 5.2 Remote Maintenance

You can run commands on the CLI or log in to the Eweb for device maintenance.

## 5.3 Hardware Maintenance

If the hardware is faulty, please contact Ruijie technical support.

### 5.3.1 Replacing the Lithium Battery

The device has a built-in lithium battery to maintain the real-time clock without external power supply.

To replace the lithium battery, please contact your distributor or technical support team. The technical personnel will use a lithium battery of the same specification for replacement.

 **Danger**

- There is the danger of explosion if the battery is replaced incorrectly. Replace the battery only with the same or equivalent type recommended by the manufacturer.
- Dispose the replaced lithium battery properly. Subjecting the battery to extremely high temperatures, extremely low air pressure, fire, or microwave oven may cause flammable liquid or gas leakage or even the danger of explosion.

# 6 Troubleshooting

## 6.1 Troubleshooting Flowchart

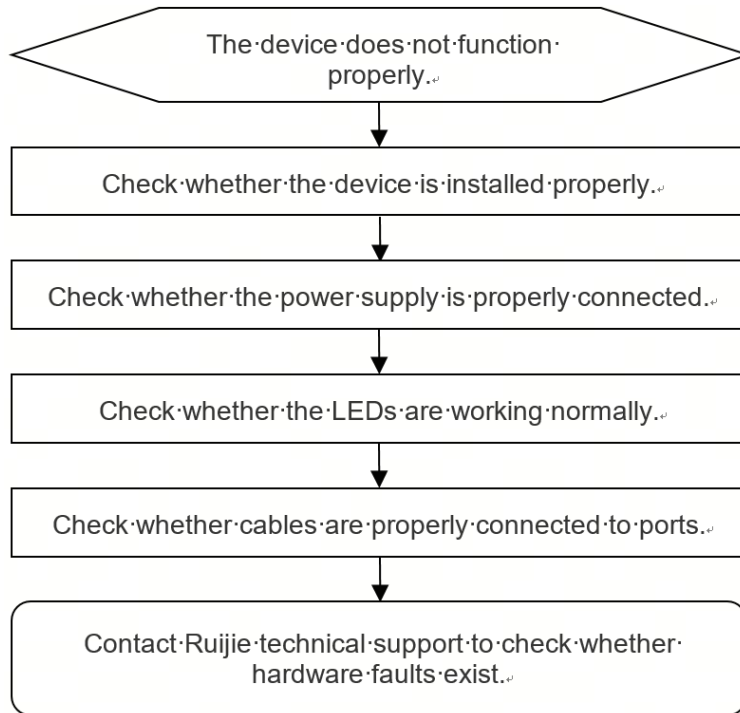

## 6.2 Common Faults

### 6.2.1 The Ethernet Port Does Not Work After the Ethernet Cable Is Plugged In

Check whether the peer device is working properly. Check whether the Ethernet cable is capable of providing the required data rate and is properly connected.

### 6.2.2 LED Is Off for a Long Time

Check whether the mains input is normal and whether the power supply is working properly.

### 6.2.3 System LED Blinks Green for a Long Time

The device needs to be initialized after powered-on. During the initialization, the LED blinks green. The LED turns solid green only after the initialization is completed.

---

**⚠ Caution**

If the LED keeps blinking green for an hour, the device initialization fails and the device is faulty.

---

## 6.2.4 Troubleshooting Power Failures

You can determine whether the power system of the RG-WS7110 is faulty based on the PWR LED on the front panel. For the status description of the LED, see [LEDs and Button](#). If an exception occurs, check the following:

- Check whether the power switch is on.
- Check whether the power source is turned on.
- Check whether the power cord is properly connected.
- Check whether the power supply meets the requirements.

---

 **Caution**

Please do not hot swap the power cord. If the PWR LED is still off after the preceding check, contact Ruijie technical support.

---

## 6.2.5 Troubleshooting System Failures

If the system works normally after power-on, system startup logs are displayed on the terminal. If the configuration system is faulty, no information is displayed or garbled characters are displayed on the terminal. If the terminal does not display any information, check the following:

- Check whether the power system is normal.
- Check whether the console port cable is properly connected.

If no information is displayed after the preceding check, the console cable may be incorrectly connected or terminal parameters may be configured incorrectly, modify the parameters of the terminal. Check the terminal parameters:

- Baud rate: 9600 bps
- Data bit: 8
- Parity check: None
- Stop bit: 1
- Flow control: None
- Terminal emulation: VT100

---

 **Note**

If the console port parameters of the device have been modified, information may be not displayed on the terminal.

---

# 7 Appendix

## 7.1 Connectors and Media

- 1000BASE-T/100BASE-TX/10BASE-T Port

The 1000BASE-T/100BASE-TX/10BASE-T is a 10/100/1000 Mbps auto-negotiation port that supports auto MDI/MDIX Crossover.

Compliant with IEEE 802.3ab, the 1000BASE-T port requires 100-ohm Category (CAT) 5/5e Unshielded Twisted Paired (UTP) or Shielded Twisted Pair (STP) with a maximum distance of 100 meters (328.08 ft.).

The 1000BASE-T port requires all four pairs of wires to be connected for data transmission. The following figure shows twisted pair connections for the 1000BASE-T port.

**Figure 7-1 1000BASE-T Twisted Pair Connections**

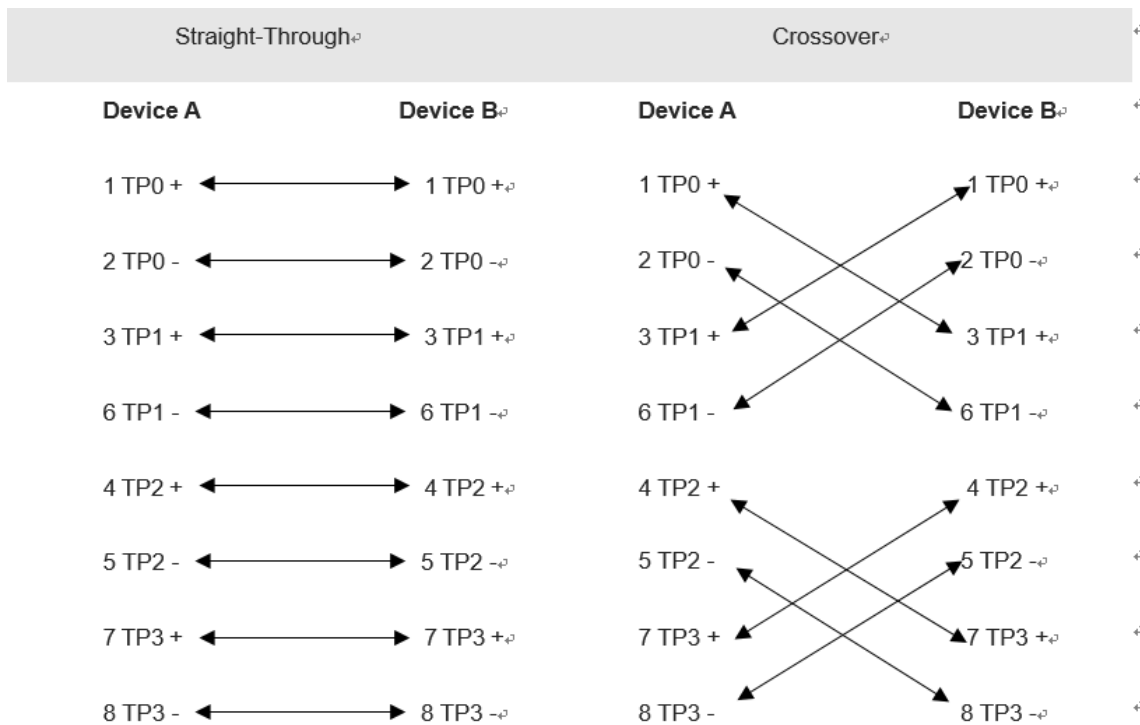

100BASE-TX/10BASE-T port can also be connected by cables of the preceding specifications. Besides, the 10BASE-T port can be connected by 100-ohm Category 3, Category 4, and Category 5 cables with a maximum distance of 100 meters (328.08 ft.). 100BASE-TX port can be connected by 100-ohm Category 5 cables with a maximum distance of 100 meters (328.08 ft.). The following figure lists definitions of pin signals for the 100BASE-TX/10BASE-T port.

**Table 7-1 100BASE-TX/10BASE-T Pin Assignments**

Pin	Connector	Plug
1	Input Receive Data+	Output Transmit Data+

Pin	Connector	Plug
2	Input Receive Data-	Output Transmit Data-
3	Output Transmit Data+	Input Receive Data+
6	Output Transmit Data-	Input Receive Data-
4, 5, 7, 8	Not Used	Not Used

The following figure shows feasible connections of the straight-through and crossover twisted pairs for a 100BASE-TX/10BASE-T port.

**Figure 7-2 100BASE-TX/10BASE-T Twisted Pair Connections**

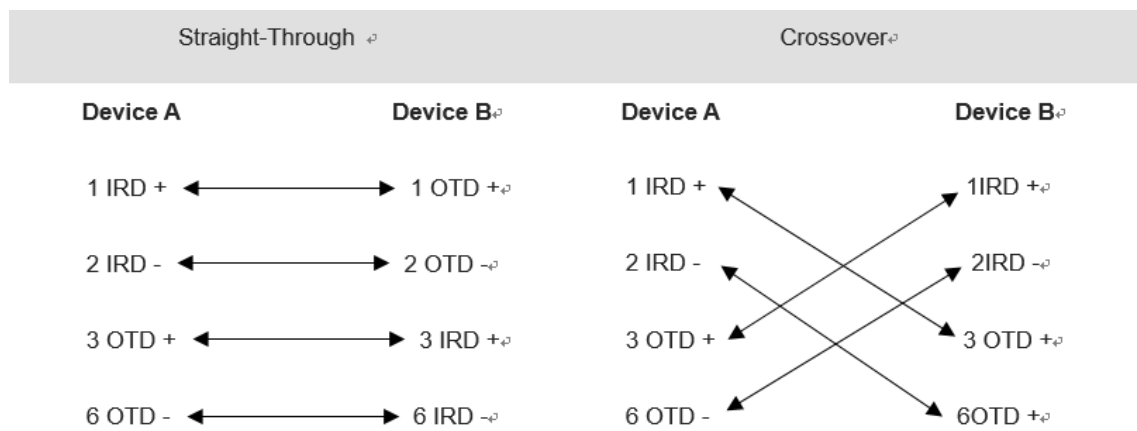

## 7.2 Cabling Recommendations

During installation, route cable bundles upward or downward along the sides of the rack depending on the actual situation in the equipment room. All adapted connectors should be placed at the bottom of the rack in an orderly manner instead of outside the rack that is easy to touch. Power cords are routed beside the rack. Top cabling or bottom cabling is adopted according to the actual situation in the equipment room, such as the positions of the DC power distribution box, AC socket, or lightning protection box.

- Requirement for the Minimum Bend Radius of an Ethernet Cable
  - The bend radius of a fixed power cord, Ethernet cable, or flat cable should be over five times greater than their respective diameters. The bend radius of these cables that are often bent or plugged should be over seven times greater than their respective diameters.
  - The bend radius of a fixed common coaxial cable should be over seven times greater than its diameter. The bend radius of the common coaxial cable that is often bent or plugged should be over 10 times greater than its diameter.
  - The bend radius of a fixed high-speed cable (such as SFP+ cable) should be over five times greater than its diameter. The bend radius of the fixed high-speed cable that is often bent or plugged should be over 10 times greater than its diameter.
- Precautions for Bundling up Cables
  - Before cables are bundled, mark labels and stick the labels to cables wherever appropriate.
  - Cables should be neatly and properly bundled in the rack without twisting or bending.

**Figure 7-3 Binding Cables**

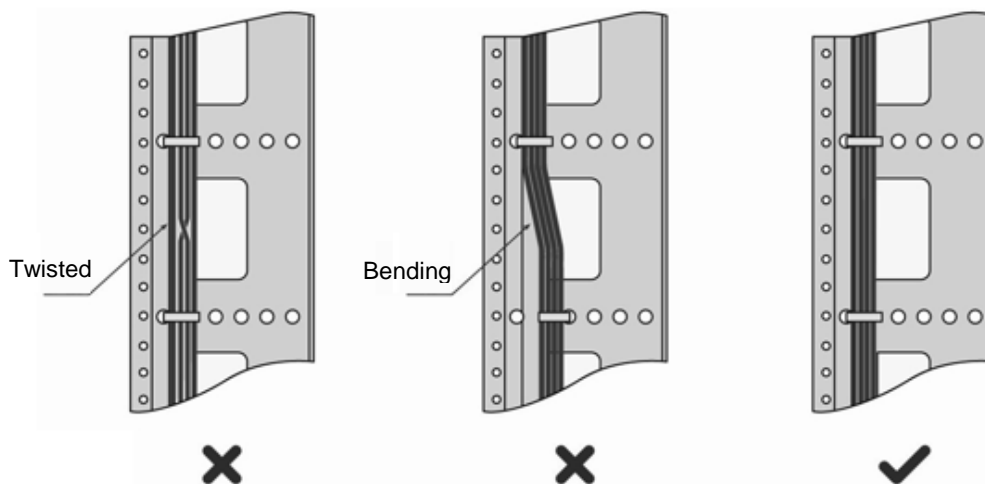

- Cables of different types (such as power cords, signal cables, and ground cables) should be separated in cabling and bundling. Mixed bundling is disallowed. When they are close to each other, you are advised to adopt crossover cabling. In the case of parallel cabling, maintain a minimum distance of 30 mm (1.18 in.) between power cords and signal cables.
- The cable management brackets and cabling troughs inside and outside the rack should be smooth without sharp corners.

- The metal hole traversed by cables should have a smooth and fully rounding surface or an insulated lining.
- Use cable ties to bundle up cables properly. Please do not connect two or more cable ties to bundle up cables.
- After bundling up cables with cable ties, cut off the remaining part. The cut should be smooth and trim without sharp corners.

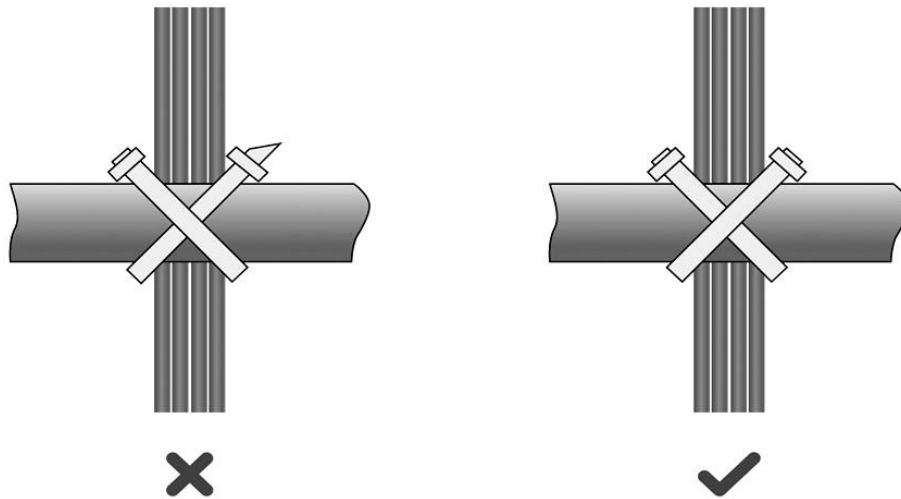
**Figure 7-4 Binding Cables**

- When cables need to be bent, please bundle them up. Avoid fastening cable ties within the bend, as this may create stress on the cables and lead to potential wire breakage.

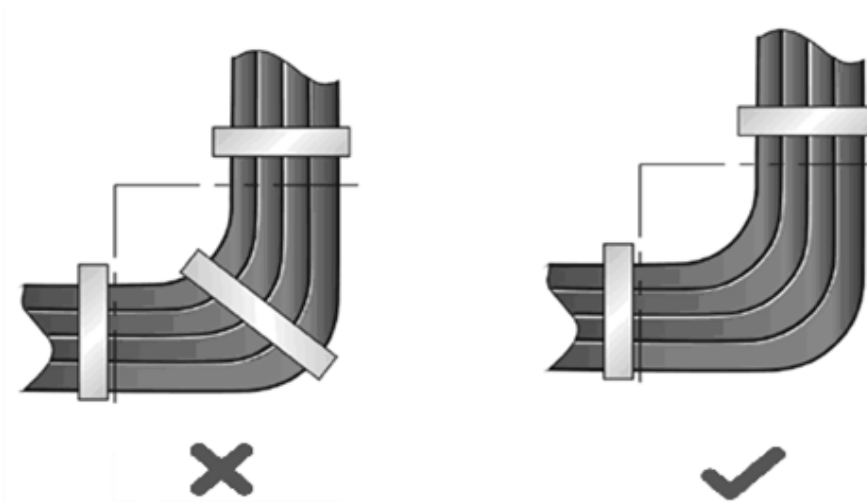
**Figure 7-5 Binding Cables**

- Cables not to be assembled or remaining parts of cables should be folded and placed in a proper position of the rack or cable trough. The proper position refers to a location that will not interfere with device operation, nor cause any damage to the device or cables during debugging.
- 220 V and -48 V power cables must not be bundled on the guide rails of moving parts.

- The power cords connected to moving parts such as door grounding cables should be reserved with some excess after being assembled. This can avoid tension or stress on power cords. After the moving part is installed, the remaining cable part should not touch heat sources, sharp corners, or sharp edges. If heat sources cannot be avoided, high-temperature cables should be used.
- When screw threads are used to fasten cable terminals, the anchor or screw must be tightly fastened, and measures should be taken to retain the terminal.

**Figure 7-6 Cable Fastening**

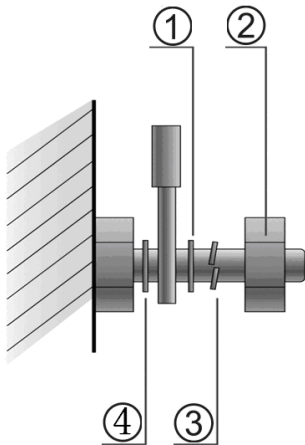

Note	① Flat washer	③ Spring washer
	② Screw nut	④ Flat washer

- Hard power cords should be fastened in the terminal connection area to prevent stress on terminal connection and cable.
- Do not use self-tapping screws to fasten terminals.
- Power cords of the same type and in the same cabling direction should be bundled up into cable bunches, with cables in cable bunches clean and straight.
- Bundle up cables using cable ties based on the following table.

Cable Bunch Diameter	Distance Between Every Binding Point
10 mm (0.39 in.)	80 mm to 150 mm (3.15 in. to 5.91 in.)
10 mm to 30 mm (0.39 in. to 1.18 in.)	150 mm to 200 mm (5.91 in. to 7.87 in.)
30 mm (1.18 in.)	200 mm to 300 mm (7.87 in. to 11.81 in.)

- Do not tie cables or bundles in a knot.
- For wiring terminal sockets (such as circuit breakers) with cord end terminals, the metal part of the cord end terminal should not be exposed outside the terminal socket when assembled.

## 7.3 Optical Transceivers

### 7.3.1 1GE SFP Transceivers

Ruijie provides 1GE SFP transceivers based on the port types. You can select a module as required. The following models and technical specifications of some 1GE SFP transceivers are listed for your reference.

**Table 7-2 Models and Technical Specifications of SFP Transceivers**

Model	Wavelength (nm)	Fiber Type	DDM Supported (Yes/No)	Transmit Power (dBm)		Receive Power (dBm)	
				Min.	Max.	Min.	Max.
MINI-GBIC-ZX80-SM1550	1550	SMF	Yes	-2	5	-23	-1
MINI-GBIC-LH40-SM1310	1310	SMF	Yes	-5	0	-23	-3
MINI-GBIC-SX-MM850	850	MMF	Yes	-9.5	0	-17	0
MINI-GBIC-LX-SM1310	1310	SMF	Yes	-11	-3	-19	-3
GE-SFP-LH40-SM1310-BIDI	1310	SMF	Yes	-5	0	-23	-3
GE-SFP-LH40-SM1550-BIDI	1550	SMF	Yes	-5	0	-23	-3
GE-SFP-LX03-SM1310-BIDI-I	1310	SMF	Yes	-9	-3	-22	-3
GE-SFP-LX03-SM1550-BIDI-I	1550	SMF	Yes	-9	-3	-22	-3

**Table 7-3 Cabling Specifications of SFP Transceivers**

Model	Connector Type	Fiber Type	Core Size (μm)	Max. Cabling Distance
MINI-GBIC-ZX80-SM1550	LC	SMF	9/125	80 km
MINI-GBIC-LH40-SM1310	LC	SMF	9/125	40 km
MINI-GBIC-SX-MM850	LC	MMF	50/125	550 m
MINI-GBIC-LX-SM1310	LC	SMF	9/125	10 km

GE-SFP-LH40-SM1310-BIDI	LC	SMF	9/125	40 km
GE-SFP-LH40-SM1550-BIDI	LC	SMF	9/125	40 km
GE-SFP-LX03-SM1310-BIDI-I	LC	SMF	9/125	3 km
GE-SFP-LX03-SM1550-BIDI-I	LC	SMF	9/125	3 km

 **Caution**

- For optical transceivers with a cabling distance of over 40 km/24.85 miles (including 40 km), install an optical attenuator to avoid overload on the optical receiver when using short-distance single-mode fibers (SMFs).
- An optical transceiver is a laser transmitter. Do not look into the light source to prevent it from burning your eyes.
- To keep the optical transceiver clean, make sure that the unused ports remain capped.

**Table 7-4 Pairing of 1GE BIDI Optical Transceivers**

Rate/Distance	Pairing Models
1000 M/3 km	GE-SFP-LX03-SM1310-BIDI-I GE-SFP-LX03-SM1550-BIDI-I

### 7.3.2 10GE SFP+ Transceivers

Ruijie provides 10GE SFP+ transceivers based on the port types. You can select a module as required. The following models and technical specifications of some 10GE SFP+ transceivers are listed for your reference. For details about the technical specifications, see *Ruijie Transceiver Installation and Reference Guide*.

**Table 7-5 Models and Technical Specifications of 10GE SFP+ Transceivers**

Model	Wavelength (nm)	DDM (Yes/No)	Fiber Type	Transmit Power (dBm)		Receive Power (dBm)	
				Min.	Max.	Min.	Max.
XG-SFP-SR-MM850	850	Yes	MMF	-5	-1	-7.5	0.5
XG-SFP-LR-SM1310	1310	Yes	SFM	-8.2	0.5	-14.4	0.5
XG-SFP-AOC3M	850	Yes	MMF	NA	NA	NA	NA
XG-SFP-AOC5M	850	Yes	MMF	NA	NA	NA	NA
XG-SFP-LR10-SM1270-BIDI-I	1270	Yes	SFM	-6.5	0.5	-14.4	0.5
XG-SFP-LR10-SM1330-BIDI-I	1330	Yes	SFM	-6.5	0.5	-14.4	0.5
2.5G-SFP-LX03-SM1310-BIDI-I	1310	Yes	SFM	-9	-3	-16	-3
2.5G-SFP-LX03-SM1550-BIDI-I	1550	Yes	SFM	-9	-3	-16	-3

**Table 7-6 Cabling Specifications of SFP+ Transceivers**

Model	Connector Type	Fiber Type	Core Size(μm)	Modular Bandwidth (MHz-km)	Max. Cabling Distance
XG-SFP-SR-MM850	LC	MMF	62.5/125	200 (OM1) 160	33 m 26 m
			50/125	2000 (OM3) 500 (OM2) 400 (OM1)	300 m 82 m 66 m
XG-SFP-LR-SM1310	LC	SFM	9/125	N/A	10 km

Model	Connector Type	Fiber Type	Core Size(μm)	Modular Bandwidth (MHz·km)	Max. Cabling Distance
XG-SFP-AOC3M	NA	MMF	50/125	N/A	3 m
XG-SFP-AOC5M	NA	MMF	50/125	N/A	5 m
XG-SFP-LR10-SM1270-BIDI-I	LC	SFM	9/125	N/A	10 km
XG-SFP-LR10-SM1330-BIDI-I	LC	SFM	9/125	N/A	10 km
2.5G-SFP-LX03-SM1310-BIDI-I	LC	SFM	9/125	N/A	3 km
2.5G-SFP-LX03-SM1550-BIDI-I	LC	SFM	9/125	N/A	3 km

**⚠ Caution**

- An optical transceiver is a laser transmitter. Do not look into the light source to prevent it from burning your eyes.
- To keep the optical transceiver clean, make sure that the unused ports remain capped.

**Table 7-7 Pairing of 10GE BIDI Optical Transceivers**

Rate/Distance	Pairing Models
10GE/10 km	XG-SFP-LR10-SM1270-BIDI-I XG-SFP-LR10-SM1330-BIDI-I